



QUALITY... PLAIN & SIMPLE®

Column Cable Shift Linkage Installation Instructions

For 1-1/2", 2" & 2-1/4" GM or Aftermarket Steering Columns and GM Transmissions (except 4L80 w/ long selector shaft, Powerglide, and 4L60E)

General Installation Notes:

Please read these instructions completely before beginning the installation. If you have any questions, please call.

Before beginning the installation, disconnect the negative battery cable and use wheel chocks to block the vehicle's wheels.

Make sure the engine, transmission, body and frame are properly grounded. We recommend using anti-seize lubricant on all aluminum threads.

Refer to Fig. 1 and Fig. 2 for the component names.

Step 1: Remove all of the existing shifter linkage from both the steering column and the transmission.

Step 2: Install the trans lever onto the transmission using the factory nut. The trans lever should point down and towards the front of the vehicle at approximately the 7:00 position. **Fig. 3**

Step 3: Remove the two center bolts on the driver side of the transmission oil pan and set them aside. The trans cable bracket will be mounted using these two bolt holes.

Some GM transmissions use standard bolts while others use metric bolts. Both standard 5/16"-18 x 1-1/4" and metric M8 x 30mm bolts have been included in this kit. Determine which pair matches the thread pitch on the pan bolts you removed from the transmission. Discard the other two new bolts, and the bolts you removed from the transmission.

Position the trans cable bracket with the tab towards the rear of the vehicle and pointing down. Install the two new pan bolts with lock washers and flat washers, with the 3/8" spacers between the trans cable bracket and the transmission pan. **Fig. 4** Leave the bracket loose so that it can be slid front to back for final adjustment.

Step 4: Remove the #10-32 nut, the two rubber boots and the first large jam nut and star washer from the end of the new shift cable. Insert the shift cable into the trans cable bracket from the rear of the vehicle. With the shift cable inserted, reinstall the star washer, nuts and boots in their original positions. Snug the large jam nuts by hand, but do not tighten at this time.

Step 5: Install the trans lever cable stud onto the end of the shift cable. When using an **aftermarket column**, insert the threaded end of the trans lever cable stud into the transmission shift lever from the transmission side into **the hole marked "A"**, and install the 1/4"-28 nylock nut. When using a **factory GM column**, attach the trans lever cable stud to **the hole marked "B"**, instead.

DO NOT OVER-TIGHTEN THE NYLOCK NUT! The trans lever cable stud has to be free to rotate in the trans lever when shifting gears.

Column Cable Shift Linkage Installation Instructions

For 1-1/2", 2" & 2-1/4" GM or Aftermarket Steering Columns and GM Transmissions
(except 4L80 with long selector shaft, Powerglide, and 4L60E)

Building American Quality... With A Lifetime Warranty!®

TOLL FREE 1-877-469-7440 • tech@lokar.com • www.lokar.com

NOTE: The shift cable is not designed for side to side pressure. When attaching the trans lever cable stud to the trans lever **DO NOT** bend the shift cable. It may be necessary to remove the trans lever from the transmission and install the trans lever cable stud onto the trans lever first, and then, reinstall the trans lever onto the transmission.

Step 6: Make sure the transmission is in Park. Pull the inner part of the shift cable out at the transmission end as far as it will go, and tighten the mounting bracket bolts. Make sure the inner part of the shift cable is fully extended when the transmission is in Park. **Fig. 5**

Step 7: Route the shift cable to the steering column. Make sure the shift cable is not in a bind and does not interfere with any moving parts or contact any parts that may melt it.

Step 8: Install the shifter cable mounting stud into the column shift cable bracket with the 3/8"-24 nylock nut, but **DO NOT OVER-TIGHTEN! The cable mounting stud has to be free to rotate in the column shift cable bracket when shifting gears.** **Fig. 6**

Step 9: Separate the two halves of the column shift cable bracket by removing the 1/4"-20 x 1/2" socket head bolts using a 3/16" Allen wrench. Position the column shift cable bracket around the steering column with the shifter cable mounting stud below the bracket. Reinstall the two 1/4"-20 x 1/2" bolts to clamp the column shift cable bracket in place, but do not fully tighten at this time. The column shift cable bracket must be positioned so that the cable mounting stud will align the shift cable with the hole in the column shift lever. Some aftermarket steering columns have an adjustable column shift lever that allows for several different mounting angles, making this easier.

Also, the column shift cable bracket and the column shift lever must be positioned so that the shift cable is pulled (not pushed) by the column shift lever when the driver moves the gear selector from Park to Drive.

(If the column shift cable bracket and the column shift lever cannot be positioned so that the cable will reach the column shift lever and pull on the cable when moving from Park to Drive, you will need to install the column cable adapter discussed in Step 11.)

Step 10: At the column end of the new shift cable, remove the #10-32 nut, the two rubber boots, and the first large jam nut and star washer. Insert the shift cable into the shifter cable mounting stud on the column shift cable bracket. With the shift cable inserted, reinstall the star washer, nuts and boots in their original positions. Snug the large jam nuts by hand, but do not tighten at this time.

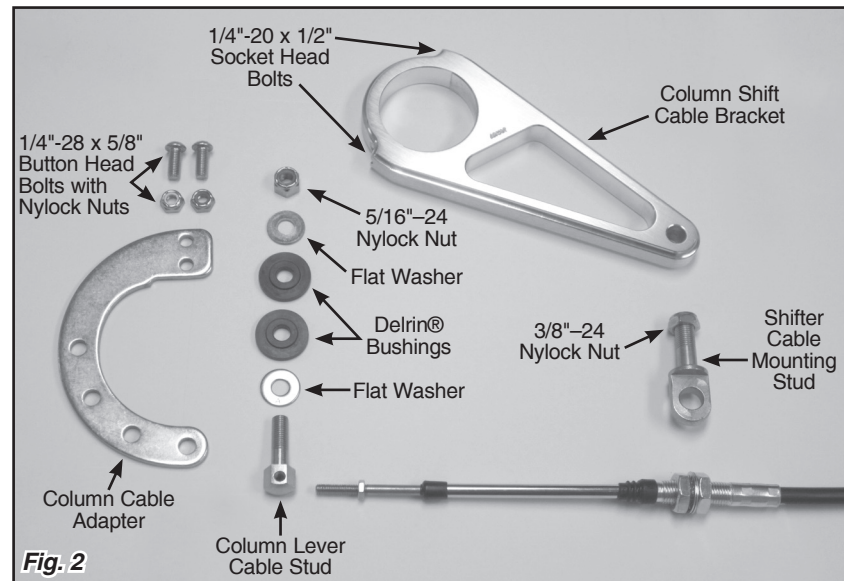
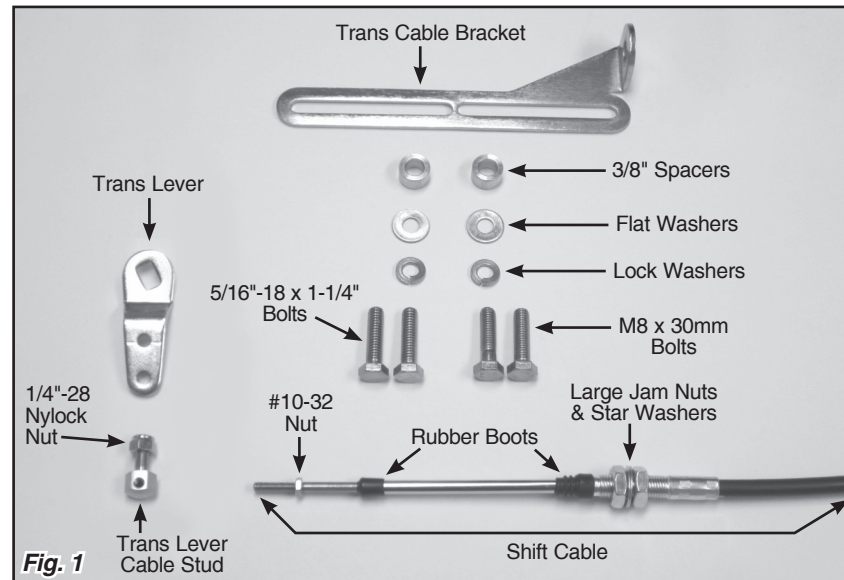

Step 11: Verify that both the transmission and the shifter are in Park. Install the column lever cable stud onto the cable. Adjust the position of the column shift cable bracket and the column shift lever (if adjustable) so that the column lever cable stud is aligned with the top side of the column shift lever.

The column shift lever could be one of several different designs, and the type of column shift lever you have will determine how the Delrin® bushings will be positioned on the column lever cable stud. If the raised shoulder in the center of the provided Delrin® bushings will fit inside the hole in the column shift lever, the Delrin® bushings will be installed with the raised shoulders facing each other inside the column shift lever. If the raised shoulder in the center of the provided Delrin® bushings will **NOT** fit inside the hole in the column shift lever, the Delrin® bushings will be installed with the raised center shoulders facing outwards.

NOTE: Some aftermarket steering columns will require that you drill out the shift linkage lever to fit the bushings. The new hole should be .625 (5/8") in diameter.

On the column lever cable stud, install a flat washer first, and then, one Delrin® bushing facing the proper direction. Insert the column lever cable stud into the column shift lever, and then install the other Delrin® bushing and flat washer. Secure it all using the 5/16"-24 nylock nut but **DO NOT OVER-TIGHTEN! The column lever cable stud has to be free to rotate inside the column shift lever when shifting gears.**

If the shift cable bracket and the column shift lever cannot be positioned so that the cable will reach the column shift lever and pull on the cable when moving from Park to Drive, you will need to install the column cable adapter.

The column cable adapter can be installed in either direction, as long as the column shift lever is still pulling on the cable when moving from Park to Drive. Position the column cable adapter on the column shift lever as shown in **Fig. 7**. The notched portion on the end of the column cable adapter should fit into the offset in the column shift lever. Drill two holes through the column shift lever to match the two holes in the column cable adapter. Install the column cable adapter using the two supplied 1/4"-28 bolts and nylock nuts.

Decide which hole in the column cable adapter will best suit your application. On the column lever cable stud, install a flat washer first, and then, one Delrin® bushing with the raised center facing the flat washer. Insert the column lever cable stud into the column cable adapter, and then install the other Delrin® bushing with the raised center section facing out, and then, the flat washer. Secure it all using the 5/16"-24 nylock nut but **DO NOT OVER-TIGHTEN! The column lever cable stud has to be free to rotate inside the column cable adapter when shifting gears.** Fig 8

Step 12: With both ends of the shift cable installed, tighten all nuts and bolts. Check for proper operation. Shift the transmission slowly through all of its positions one gear at a time. Check in each position that the cable does not come in contact with the column. This usually occurs when the column is shifted into the low gear position.

If the cable is touching the column in any of the gears selected, STOP and do not shift any further. This can cause the cable to break. Loosen the column shift cable bracket and rotate it so the cable moves away from the column, and then, re-tighten the column shift cable bracket. In some cases, in order to get enough travel on the cable, it may be necessary to slot the holes in the column cable adapter where it bolts to the column shift lever, and rotate the opposite end further away from the steering column.

It will most likely be necessary to readjust the cable, especially in order to make the column shift indicator work correctly. For coarse adjustments, you will need to loosen the jam nuts on the shift cable and move to the desired adjustment. For fine adjustments, you will need to adjust the cable studs at the ends of the cable.

Step 13: Once all adjustments have been made, verify that everything works properly and that neither the shift cable nor any of its components interfere with any other moving parts.

If you installed the column cable adapter, you can now cut off any excess length that is not required.

