



QUALITY... PLAIN & SIMPLE®

## Floor Mount Shifter Cable Conversion Kit Installation Instructions

### General Installation Notes:

Please read these instructions completely before beginning the installation. If you have any questions, please call.

Before beginning the installation, disconnect the negative battery cable and use wheel chocks to block the vehicle's wheels.

Make sure the engine, transmission, body and frame are properly grounded.

All Lokar Installation Instructions can be found by visiting [www.lokar.com/instructions.html](http://www.lokar.com/instructions.html).

Refer to Fig. 1 through Fig. 7 for the component names.

This Kit is designed to convert an existing, previously installed, Lokar Floor Mount Shifter with solid rod linkage to cable operation.

### Tools and Materials Required:

- Standard Allen wrenches: 5/32", 3/16", 7/32"
- Wrench or Socket Sizes: 3/8", 7/16", 1/2", 9/16", 7/8", 15/16", 13mm (metric transmissions only)
- Tape Measure
- Drill and 5/16" drill bit

Lokar Floor Mount Shifter Cable Conversion Kits are designed to fit specific transmissions. Before installing the Conversion Kit, verify you have the proper model for your transmission. If your Conversion Kit does not seem to connect to the transmission properly, do not make modifications during installation as this may void your warranty. Call for assistance.

The Conversion Kit must be fully installed into the vehicle before attempting to make any adjustments.

The shifter lever is designed to lock in Park and in Neutral. You must depress the release button in the top of the shifter knob in order to shift out of Park or Neutral. To shift from Park directly to Drive (or Overdrive), depress the release button and hold it down while moving the shifter lever, and the shifter lever will stop in the Drive (or Overdrive) position. Once you release the button, the shifter lever can be moved into the next lower gear. You must depress the button to shift down again.

**Step 1:** Place the shifter in Park. Using a 5/32" Allen wrench and a 7/16" wrench or socket, remove the 1/4"-28 button head bolt and nylock nut from each of the rod ends on the threaded rod on your existing shifter.

**Step 2:** Make sure the transmission is in Park by rotating the original trans gear lever or trans arm clockwise as far as it will go. Remove the existing trans gear lever/trans arm from the transmission selector shaft.

# Floor Mount Shifter Cable Conversion Kit Installation Instructions

Building American Quality... With A Lifetime Warranty!®

TOLL FREE 1-877-469-7440 • [tech@lokar.com](mailto:tech@lokar.com) • [www.lokar.com](http://www.lokar.com)

## All Transmission Types:

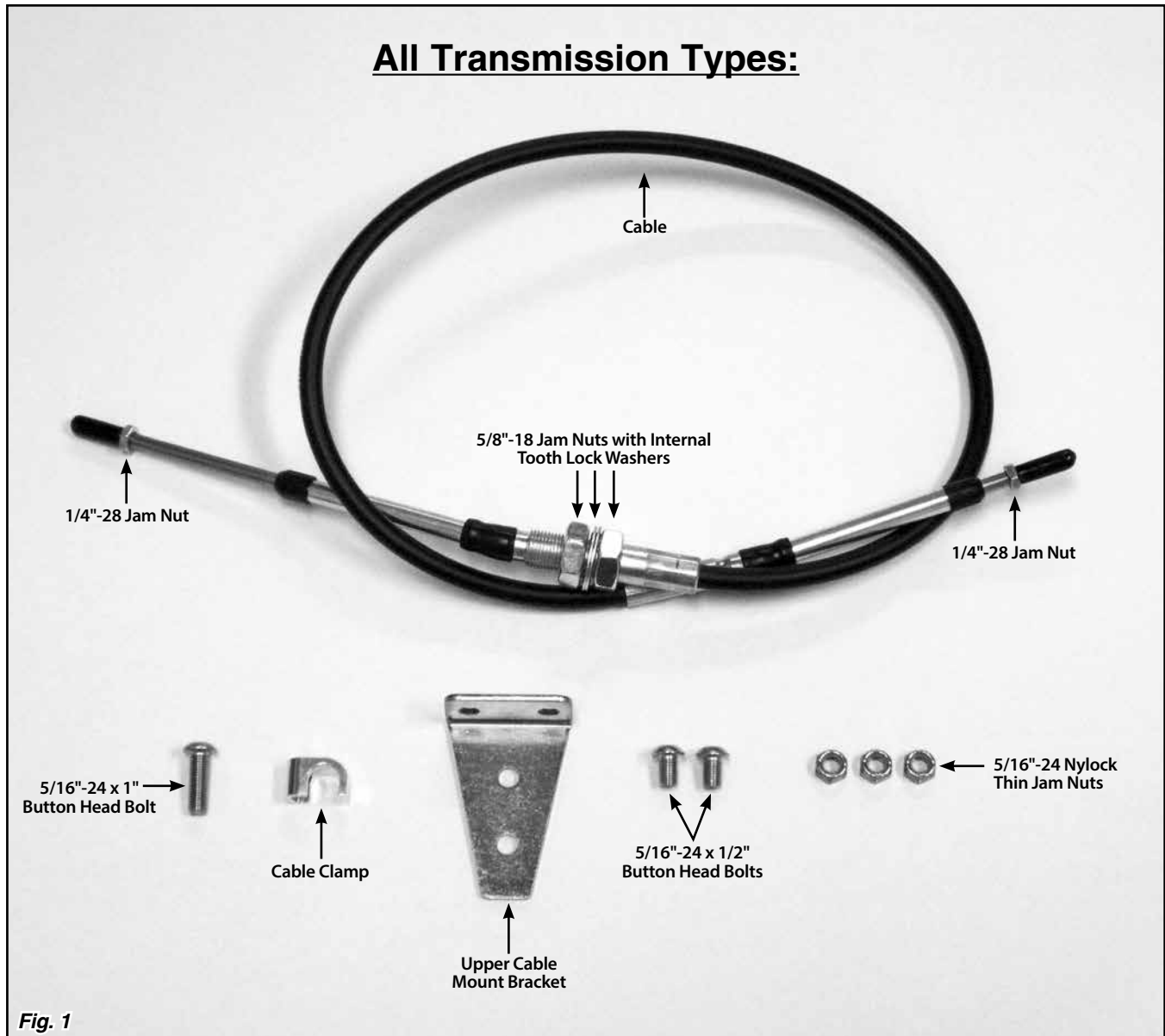

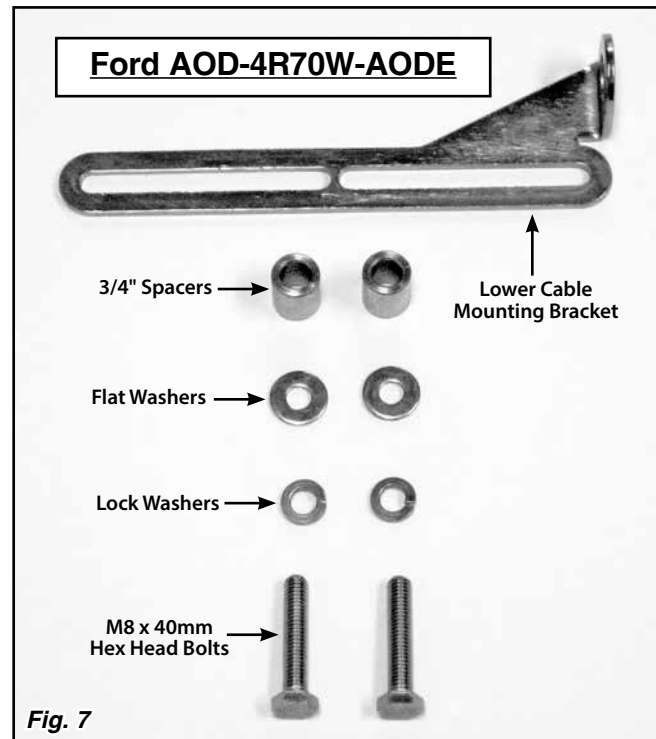
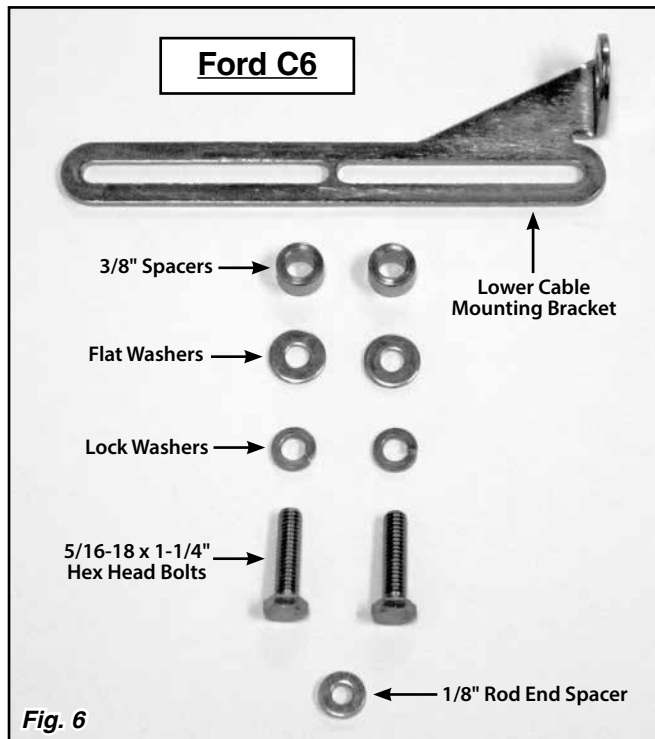
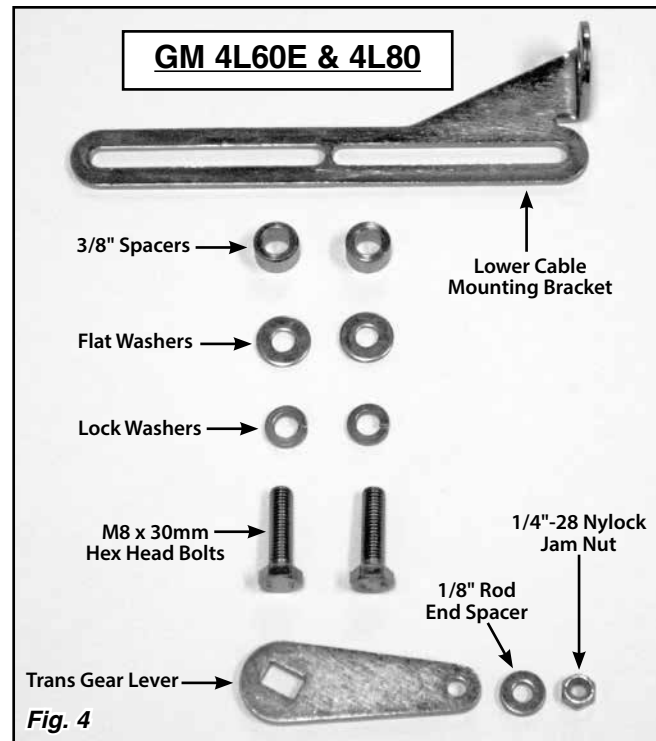
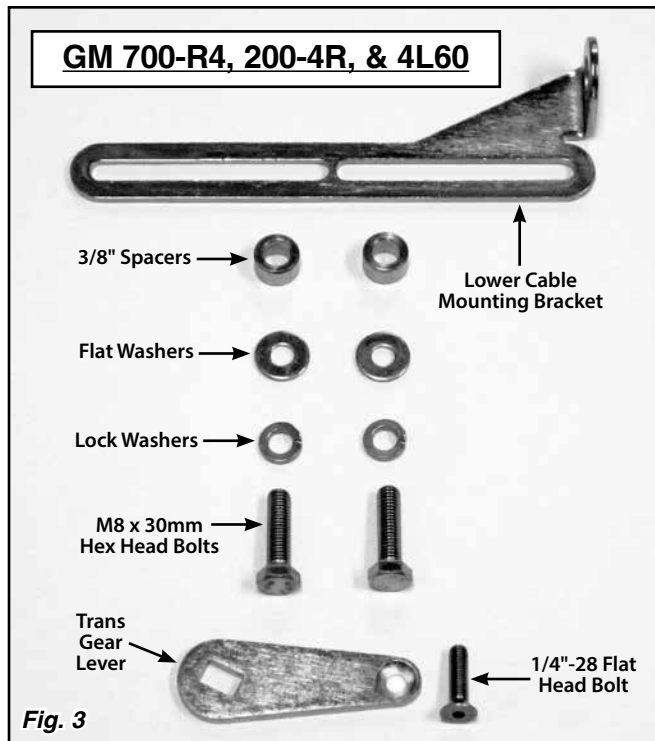
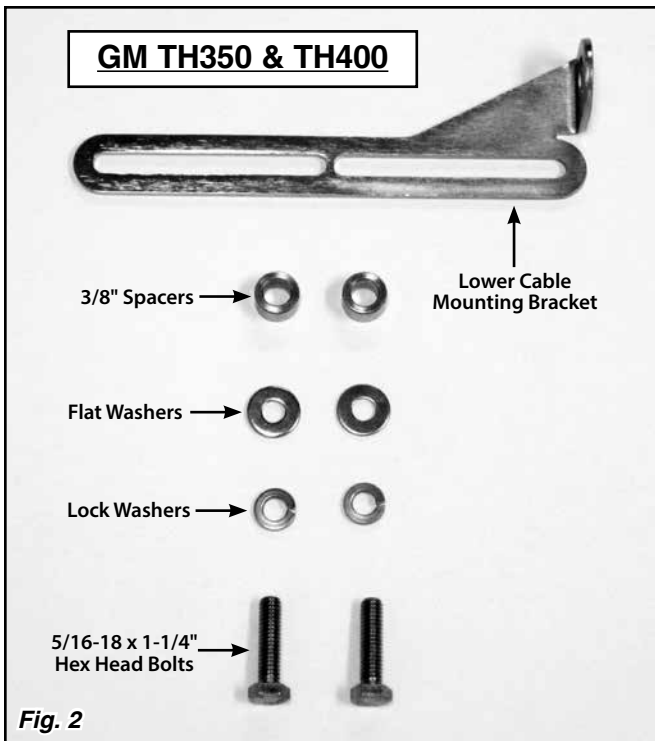

**Step 2, continued: GM TRANSMISSIONS:** On a TH350 or TH400, install your existing Lokar trans gear lever pointed down and towards the front. On a 700-R4, 200-4R, 4L60, 4L60E and 4L80, install the new Lokar trans gear lever so the trans gear lever is in the furthest forward position. **Fig. 8** This is so the cable will have full travel. The bolt hole in the trans gear lever on the 700-R4, 200-4R, and 4L60 transmissions is chamfered on one side. The chamfered side must face towards the transmission. This is required for clearance from the oil pan when the transmission is in low and second gears.

Secure the trans gear lever with the existing nut. **Fig. 9**

**FORD TRANSMISSIONS:** On C4 and C6 transmissions, reinstall the existing Lokar trans arm pointed down and towards the front. The 1/4" hole in the end of the trans arm needs to be aligned directly below the band adjustment nut on the side of the transmission. Tighten the nylock nut on the pinch bolt to hold the trans arm in position on the selector shaft. **Fig. 10** On AOD-4R70W-AODE transmissions, place the existing Lokar trans arm in the Park position with the tip of the arm pointing down and forward, at approximately the 7:30 position. **Fig. 11**

**Step 3, GM TRANSMISSIONS:** Install the lower cable mounting bracket on the driver side of the transmission pan, using the provided longer bolts, lock washers, flat washers, and 3/8" spacers. Do not tighten the bolts yet. Most TH350 and TH400 transmissions use standard thread bolts (5/16"-18 x 1-1/4"). 700-R4, 200-4R, 4L60, 4L60E, and 4L80 transmissions use metric bolts (M8 x 30mm). The TH350 uses the two rearmost pan bolts on the driver side. TH400, 700-R4, 200-4R, 4L60, 4L60E, and 4L80 use the two pan bolts directly behind the selector shaft. **Fig. 12**

**Step 3, FORD TRANSMISSIONS:** On a C4, remove the lower two tail housing bolts from the driver side of the transmission. Install the C4 lower cable mounting bracket onto the driver side of the tail housing, using the provided 3/8"-16 x 1-1/4" button head bolts and lock washers. **Fig. 13**

On C6 and AOD-4R70W-AODE transmissions, remove the two transmission pan bolts directly behind the selector shaft. Install the lower cable mounting bracket using the provided spacers and bolts. C6 uses 3/8" spacers and 5/16"-18 x 1-1/4" bolts with flat washers and lock washers, and AOD-4R70W-AODE uses 3/4" spacers and M8 x 40mm bolts with flat washers and lock washers. **Fig. 12**

**Step 4:** Make sure the shifter lever and the transmission are both in the Park position. Remove the first 5/8"-18 jam nut (15/16" wrench size) and one of the internal tooth lock washers from the cable. Install the cable into the lower cable mounting bracket, and then reinstall the lock washer and jam nut onto the cable.

**Step 5:** Make sure the 1/4"-28 jam nuts are installed on each end of the cable. Then, install the rod ends onto the cable, threading them on approximately halfway. Do not tighten the jam nuts against the rod ends yet.

**Step 6:** The inner cable needs to be fully extended all the way out at the transmission end when it is attached to the trans gear lever/trans arm. Pull the inner cable out as far as it will go. Adjust the position of the lower cable mounting bracket (all except C4), the position of the cable itself in the bracket, and/or the rod end so the hole in the rod end lines up with the hole in the trans gear lever/trans arm with the inner cable fully extended and the transmission in Park. Attach the rod end at the transmission to the trans gear lever/trans arm, using the 1/4"-28 x 1" button head bolt (or flat head bolt for 700-R4, 200-4R and 4L60), flat washer, and nylock nut. A button head type bolt may be installed in either direction. Make sure the rod end is sandwiched between the flat washer and the trans gear lever/trans arm.

- **TH350 and TH400:** The rod end attaches to the outside of the trans gear lever, away from the transmission. **Fig. 14 & 16**
- **700-R4, 200-4R, and 4L60:** The flat head bolt is installed from the inside of the trans gear lever, and the rod end attaches to the outside of the trans gear lever, away from the transmission. **Fig. 14 & 17**
- **4L60E, 4L80E:** The rod end attaches to the inside of the trans gear lever, towards the transmission. The 1/8" rod end spacer is required on some transmissions for proper alignment. If needed, the spacer goes between the rod end and the trans gear lever. **Fig. 14 & 18**

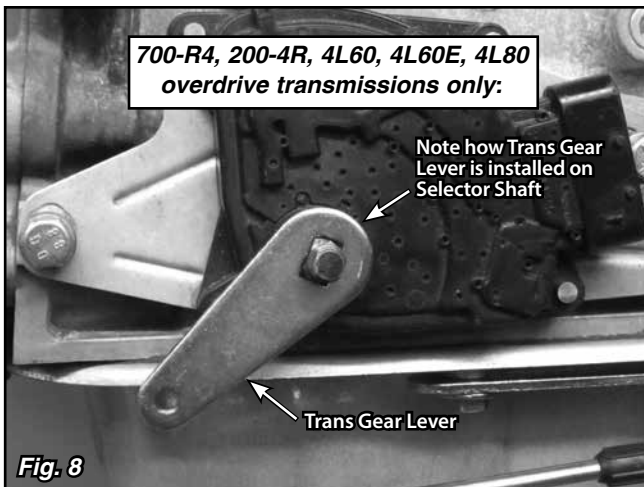

**Fig. 8**

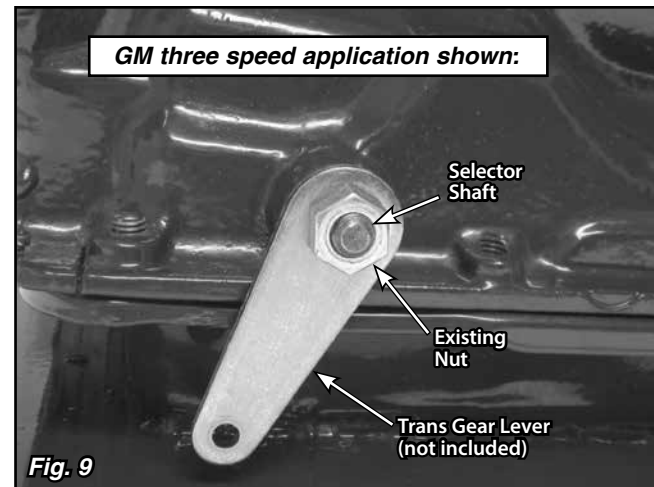

**Fig. 9**

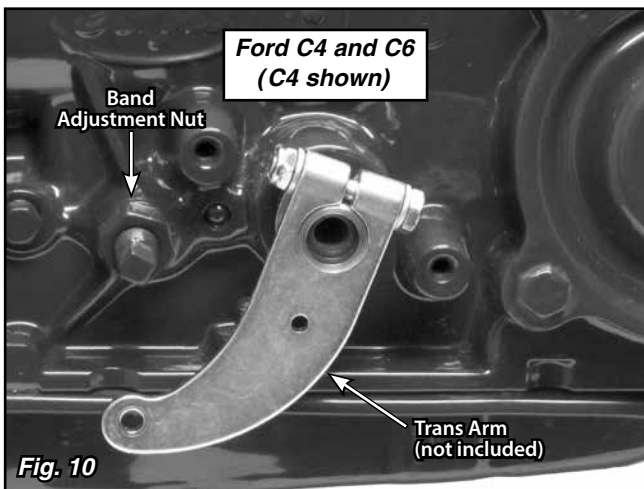

**Fig. 10**

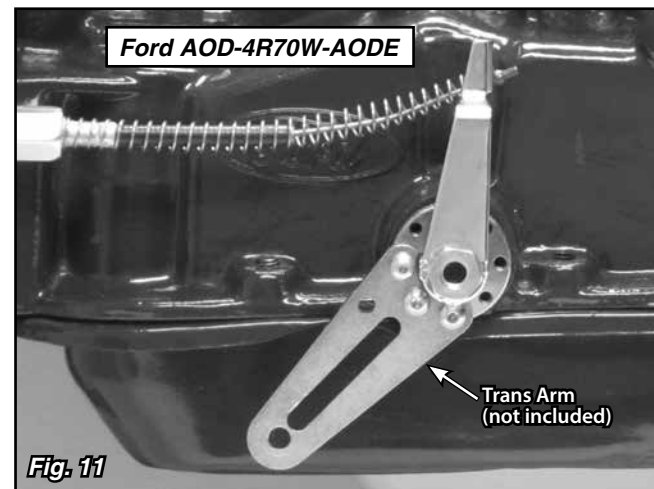

**Fig. 11**

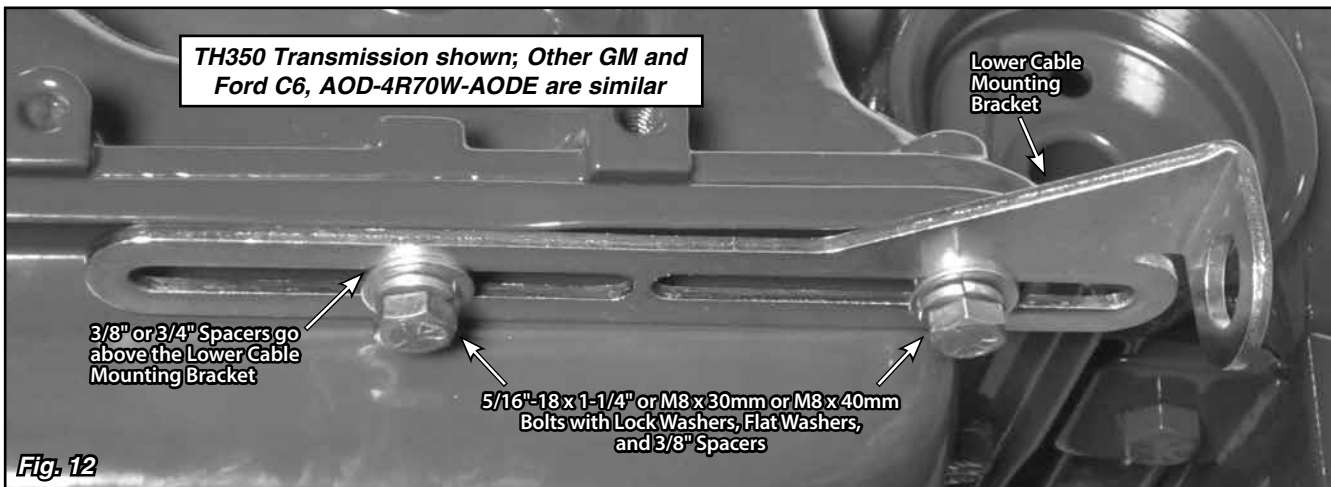

**Fig. 12**

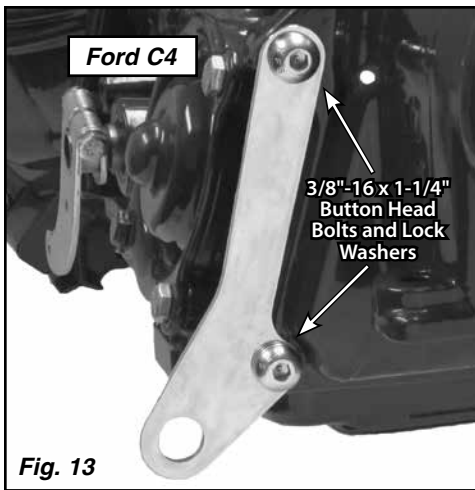

Fig. 13

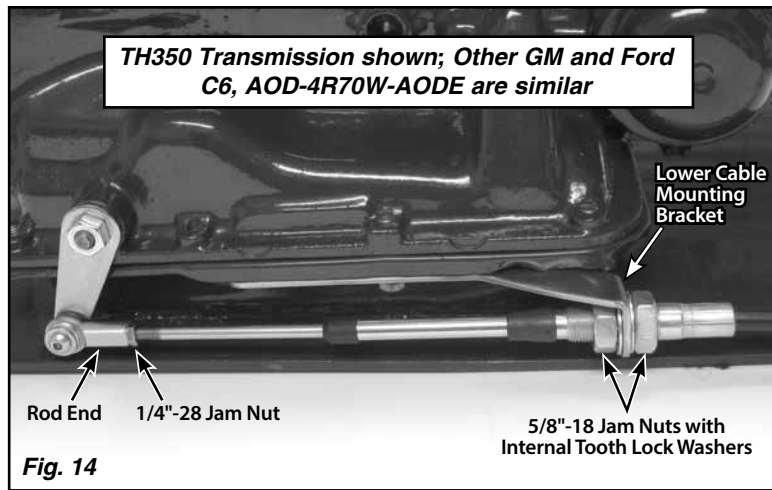

Fig. 14

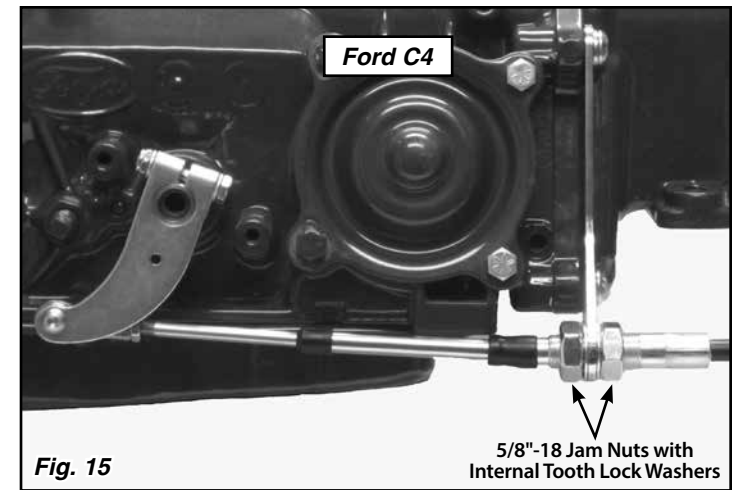

Fig. 15

**GM three speed transmissions:**

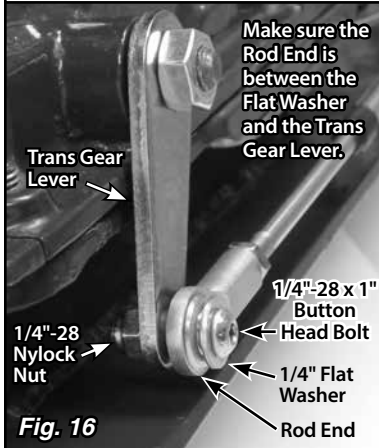

Fig. 16

**700-R4, 200-4R, 4L60: Install bolt from inside Trans Gear Lever**

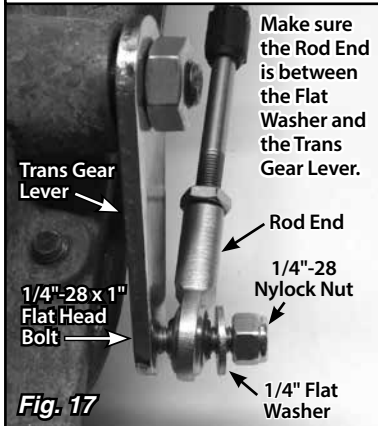

Fig. 17

**4L60E & 4L80: Rod End goes on inside of Trans Gear Lever**

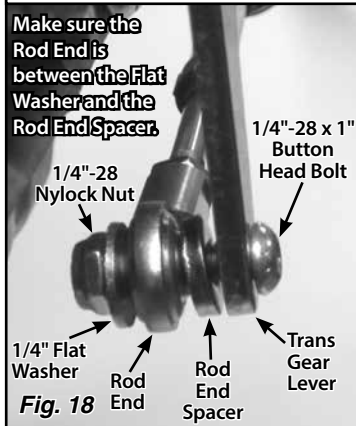

Fig. 18

**Ford C4: Rod End goes on inside of Trans Arm**

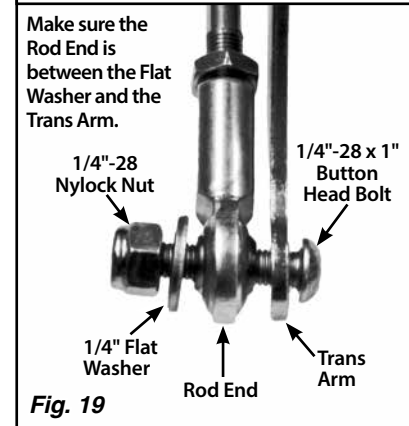

Fig. 19

**Ford C6: Rod End goes on outside of Trans Arm**

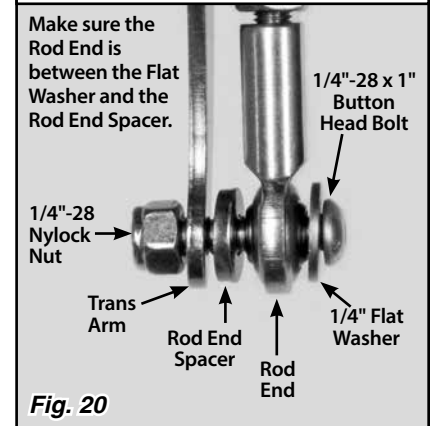

Fig. 20

**Step 6, continued:**

- **C4:** The rod end attaches to the inside of the trans arm, towards the transmission. **Fig. 15 & 19**
- **C6:** The rod end will be positioned on the outside of the trans arm, away from the transmission. The 1/8" rod end spacer goes in between the rod end and the trans arm. **Fig. 13 & 20**
- **AOD-4R70W-AODE:** The rod end attaches to the outside of the trans arm, away from the transmission. **Fig. 13 & 21**

**Step 7:** Once the rod end is attached to the trans gear lever/trans arm, tighten the lower cable mounting bracket bolts.

**Step 8:** Route the cable up to the Shifter and attach the other rod end to the quad shift lever using the existing 1/4"-28 x 1" button head bolt, flat washer, and nylock nut. **Fig. 22** The button head bolt can be installed from either direction, but make sure the rod end is sandwiched between the quad shift lever and the flat washer. When routing the cable, make sure it is not touching the exhaust or any moving parts. The cable should be routed as smoothly as possible without any sharp bends.

**Step 9:** Position the upper cable mounting bracket up against the bottom of the floor and next to the cable, aligned with the retaining groove on the cable. Align the upper cable mounting bracket with the quad shift lever, where the cable can push and pull in a smooth motion.

**NOTE:** The location of the upper cable mounting bracket is an important factor in how smoothly the Shifter operates, so make sure it is aligned correctly.

Determine how the cable clamp should be oriented on the upper cable mounting bracket and which bolt hole should be used for the best alignment with the quad shift lever. The cable clamp can be installed with the bolt above or below the cable. Insert the 5/16"-24 x 1" button head bolt into the cable clamp, and position the cable clamp on the cable, making sure the bolt is seated in the retaining groove. **Fig. 23**

Install the cable clamp and 5/16"-24 x 1" button head bolt on to the upper cable mounting bracket and secure with a nylock nut. **Fig. 24**

**AOD-4R70W-AODE: Rod End goes on outside of Trans Arm**

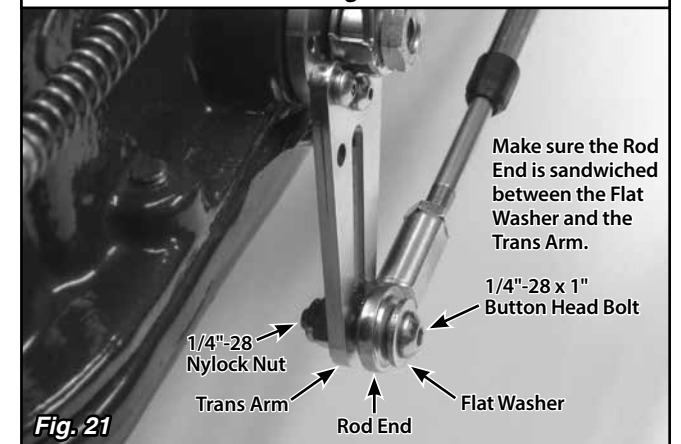

Fig. 21

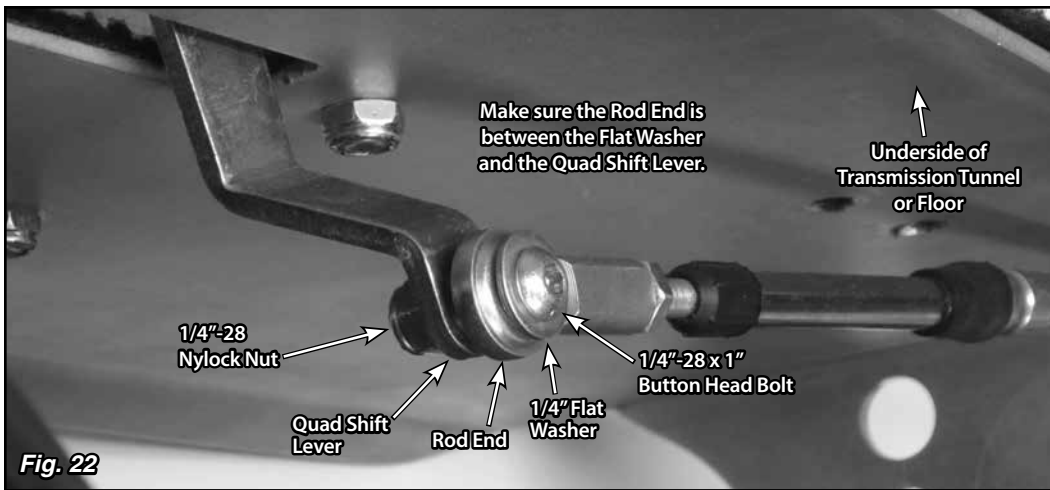

Fig. 22

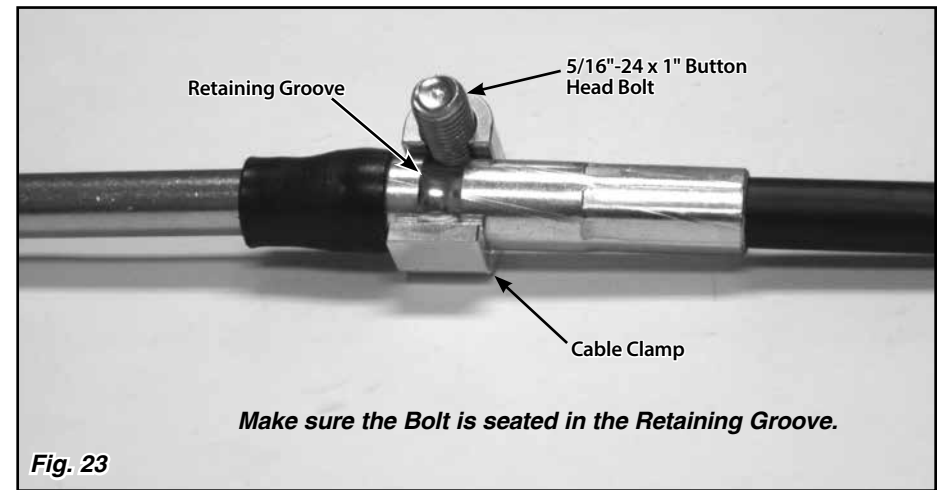

Fig. 23

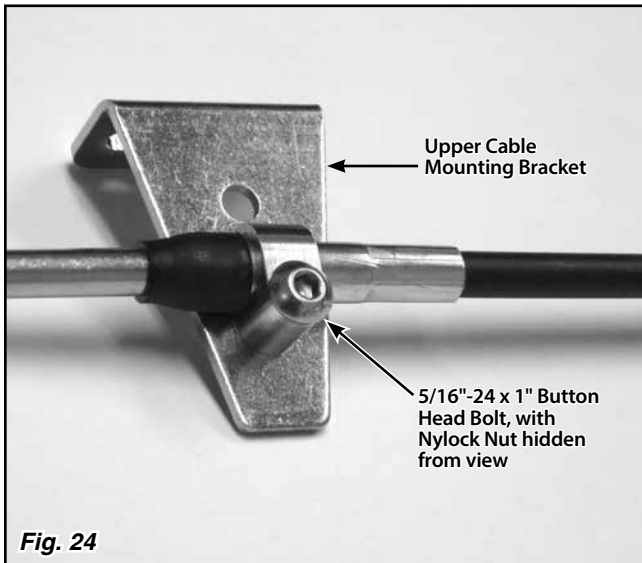

Fig. 24



Fig. 25

**Step 10:** Make sure the location chosen for the cable clamp on the upper cable mounting bracket will allow the cable to go straight to the hole in the quad shift lever without binding in any direction. Before drilling the bolt holes in the floor, be sure everything is mocked up correctly and if possible, clamp the upper cable mounting bracket in place and check operation of the Shifter. Mark the center of the holes, center punch the marks, and drill both holes using a 5/16" drill bit.

**Step 11:** Mount the upper cable mounting bracket to the floor using the 5/16"-24 x 1/2" button head bolts and nylock jam nuts. **Fig. 25**

**Step 12:** Check the adjustment of the shifter cable by placing the shifter lever all the way forward into the Park position. Make sure the release button still moves up and down freely. The release button should be flush with the knob in Park and Neutral. In the Reverse position, you cannot pull the lever back into Neutral without depressing the release button.

**Step 12, continued:**

While the shifter lever is in the Park position, make sure the transmission is firmly in the Park detent, with no tension on the cable. You can verify there is no tension on the cable by removing the 1/4"-28 x 1" bolt with nylock nut attaches the rod end to the quad shift lever or the trans gear lever/trans arm at either end of the cable. Make sure the hole in the rod end exactly aligns with the hole in the quad shift lever or trans gear lever/trans arm. The bolt should pass freely through both holes at the same time without binding. Do not force the holes to line up.

If the holes are not aligned, use the 5/8"-18 jam nuts at the lower cable mounting bracket to get the adjustment close. Then, you can fine-tune it by adjusting the rod ends until you can slide the bolt in and out without putting tension on the cable. Make sure the quad shift lever and trans gear lever/trans arm do not move during the adjustment procedure. Also, make sure the inner cable is still fully extended at the transmission end.

**Step 12, continued:**

Use this adjustment routine until the bolts will pass freely in and out of both of the rod ends and the quad shift lever and trans gear lever/trans arm. Reinstall the 1/4"-28 nylock nuts and the flat washers onto the bolts and tighten.

Once you have the shifter cable adjusted correctly, tighten the 1/4"-28 jam nuts on the ends of the cable, and the 5/8"-18 jam nuts at the lower cable mounting bracket. Double check the operation of your shifter's neutral safety switch. If the engine will start in any gear other than Park or Neutral, follow the adjustment procedure outlined in your original shifter installation instructions.

**Figs. 26 - 29** show completed installations.

Fig. 26

GM Applications (TH350 shown):

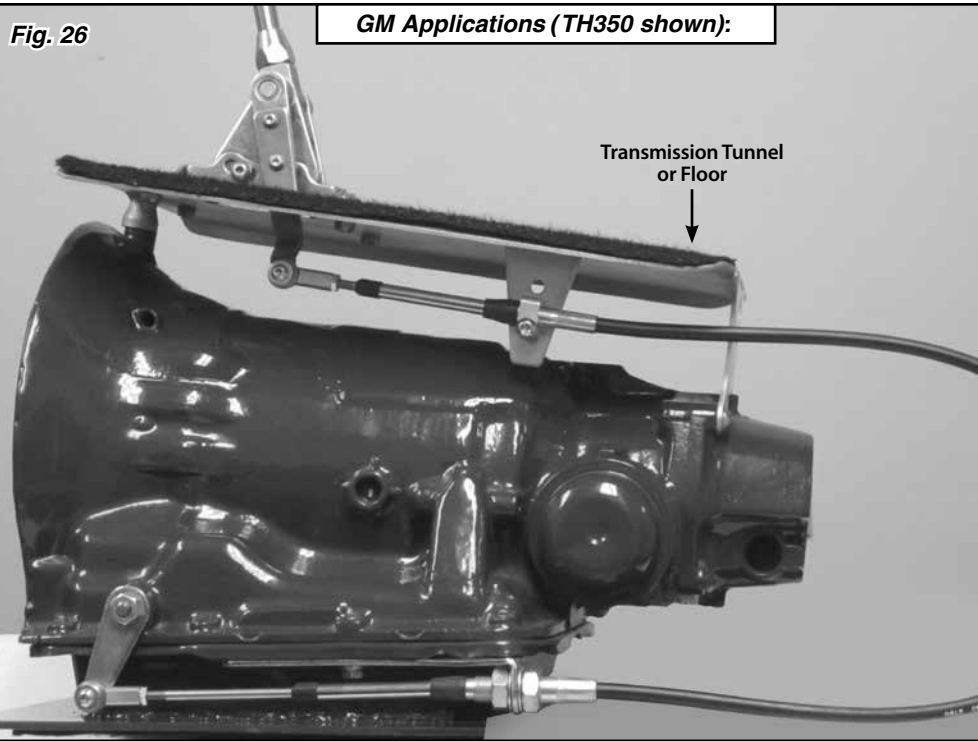

Fig. 27

Ford C4

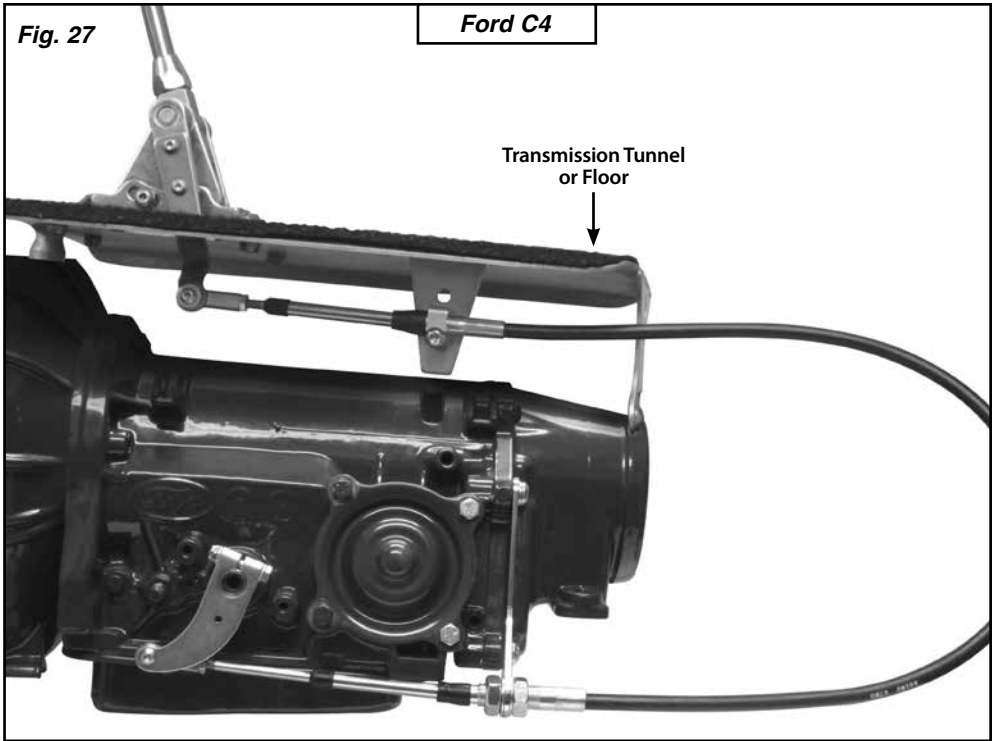

Fig. 28

Ford C6

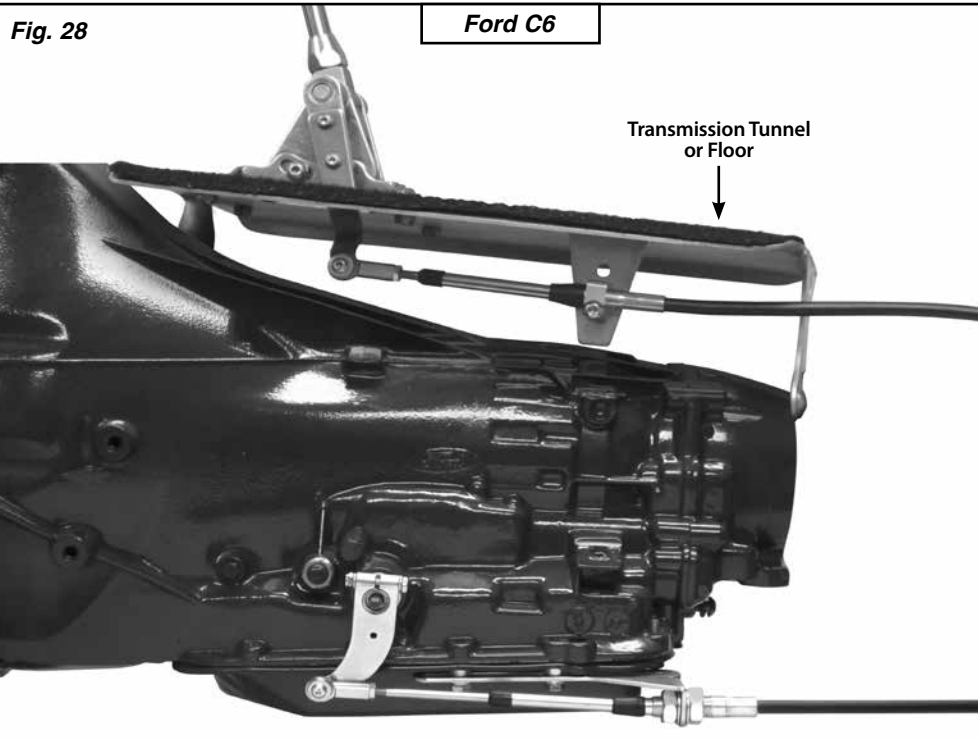

Fig. 29

Ford AOD-4R70W-AODE

